

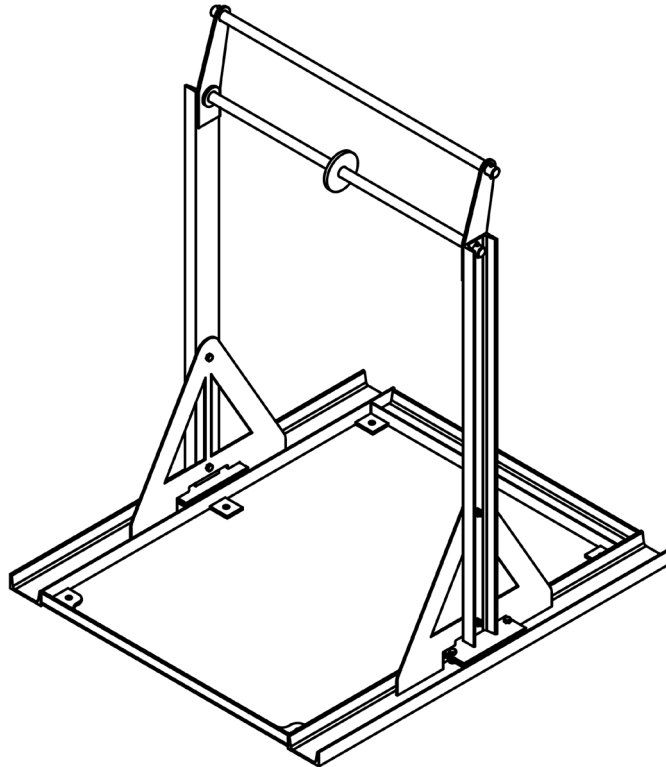

FORK-R-54 Fork Extension Storage Rack Instruction Manual



Receiving Instructions

After delivery, remove the packaging from the product. Inspect the product closely to determine whether it sustained damage during transport. If damage is discovered, record a complete description of it on the bill of lading. If the product is undamaged, discard the packaging.

NOTE: The end-user is solely responsible for confirming that product design, use, and maintenance comply with laws, regulations, codes, and mandatory standards applied where the product is used.

Technical Service & Replacement Parts

For answers to questions not addressed in these instructions and to order replacement parts, labels, and accessories, call our Technical Service and Parts Department at (260) 665-7586. The Department can also be contacted online at <https://www.vestil.com/page-parts-request.php>.

Electronic Copies of Instruction Manuals

Additional copies of this instruction manual may be downloaded from <https://www.vestil.com/page-manuals.php>.

Table of Contents

Specifications.....	2
Signal Words.....	2
Safety Instructions.....	3
Exploded View & Bill of Materials.....	3
Assembly.....	4 - 5
Using the Rack.....	5
Record of Satisfactory Condition.....	6
Inspections & Maintenance.....	6
Labeling Diagram.....	6
Limited Warranty.....	7

SPECIFICATIONS

Dimensions, capacity, and net weight information appear in the following diagrams and table.

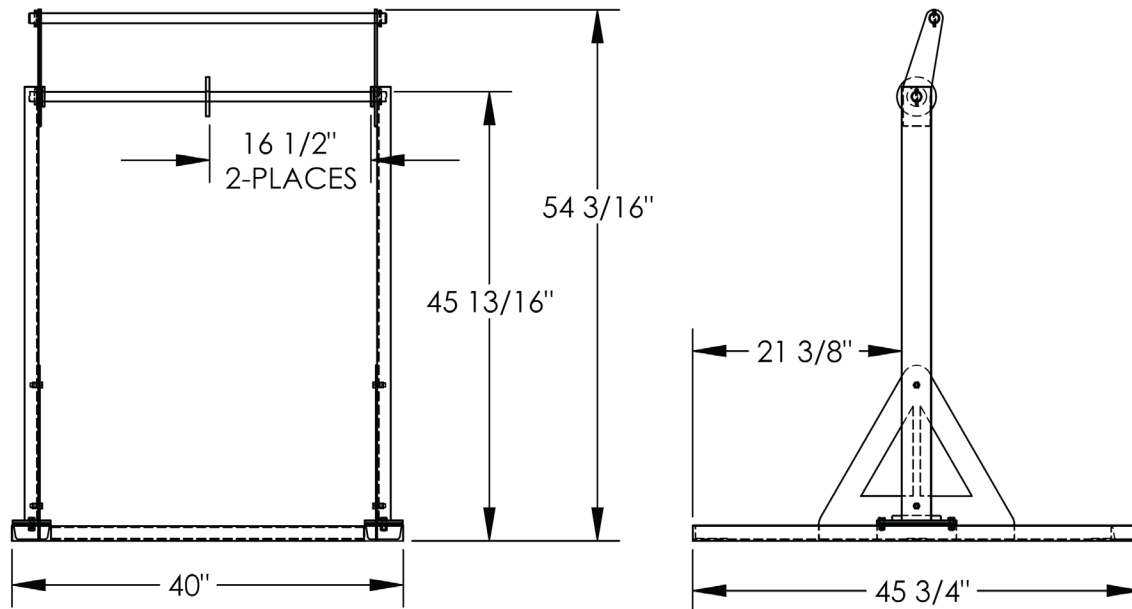

Model	Dimensions (W x D x H)	Minimum fork length	Capacity	Net weight
FORK-R-54	40 in. x 45 ³ / ₄ in. x 54 ³ / ₁₆ in. 102 cm x 116.2 cm x 137.6 cm	60 in. 152 cm	400 lb. 181.8 kg	132 lb. 60 kg

SIGNAL WORDS

This manual uses SIGNAL WORDS to draw attention to uses of the product that could result in personal injuries, as well as the probable seriousness of those injuries. Other signal words call attention to uses likely to cause property damage. Signal words used in this manual appear below along with the definition of each word.



DANGER

Identifies a hazardous situation which, if not avoided, WILL result in DEATH or SERIOUS INJURY. Use of this signal word is limited to the most extreme situations.



WARNING

Identifies a hazardous situation which, if not avoided, COULD result in DEATH or SERIOUS INJURY.



CAUTION

Indicates a hazardous situation which, if not avoided, COULD result in MINOR or MODERATE injury.



NOTICE

Identifies practices likely to result in product/property damage, such as operation that might damage the product.

SAFETY INSTRUCTIONS

We strive to identify all hazards that could occur while using our products, but no manual can address every risk. The most effective means for avoiding injury is to exercise sound judgment whenever using this device. Read the entire manual carefully before installing, using, or servicing the product. Vestil recommends that you contact its [Technical Service Department](#) (the "TSD") if you have any questions about instructions in this manual. Contact the TSD if you believe that a necessary instruction is missing or inaccurate.

WARNING

Improper or careless use of this product might result in serious personal injuries.

- **Read and understand the entire manual before assembling, using or servicing the product.** Read the manual to refresh your understanding of proper use and maintenance procedures as necessary.
- Always apply forklift operation techniques learned during training.
- DO NOT allow people to stand or sit on this rack.
- DO NOT approach the rack with a forklift or attempt to insert the forks into extensions stored on the rack if people are nearby. Coworkers should stand at a safe distance from the rack before approaching it with a forklift.
- DO NOT use the rack unless it is solidly anchored to the floor.
- DO NOT use the rack in corrosive environments.
- DO NOT perform maintenance on the rack UNLESS it is unloaded. Remove all fork extension stored on the rack until maintenance is finished. ONLY install manufacturer-approved replacement parts.
- DO NOT use the rack unless it is in normal operating condition. The unit should be square and rigid and firmly anchored to the floor, the bar stiffeners (see [Exploded View](#)) should not be warped or broken.
- DO NOT use the rack UNLESS all labels are in place and readable. See [Labeling diagram](#) on p. 6.
- DO NOT modify this product in any way. Modifications automatically void the [Limited Warranty](#) and might make the rack unsafe to use.

EXPLODED VIEW & BILL OF MATERIALS

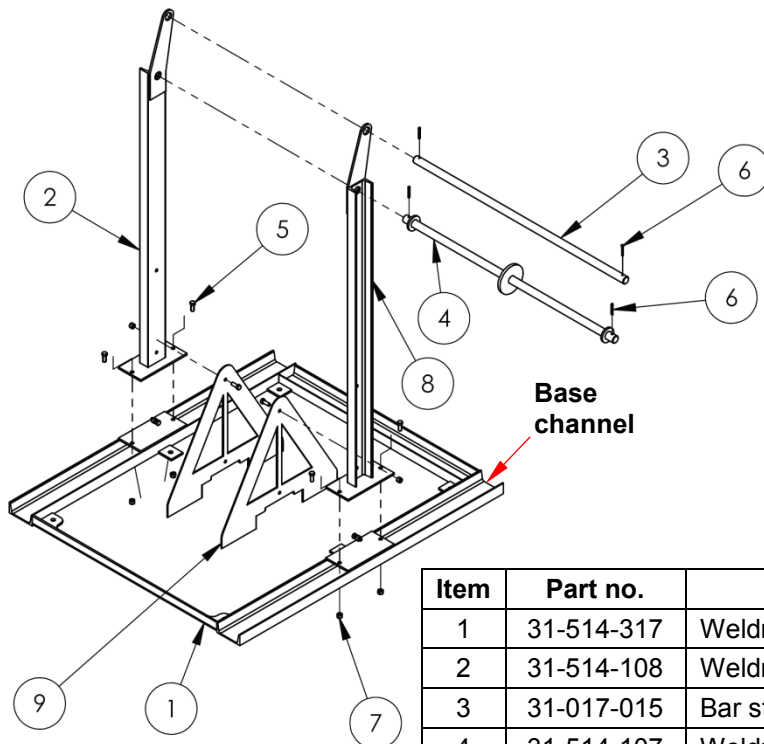

Item	Part no.	Description	Qty.
1	31-514-317	Weldment, base	1
2	31-514-108	Weldment, upright, right side	1
3	31-017-015	Bar stiffener, round	1
4	31-514-107	Weldment, lower bar stiffener	1
5	11105	$\frac{3}{8}$ in. – 16 x 1in. HHCS #2 zinc-plated bolt	8
6	65125	$\frac{3}{16}$ in. x $1\frac{1}{2}$ in. zinc-plated cotter pin	4
7	37024	$\frac{3}{8}$ in. nylock nut	8
8	31-514-110	Weldment, upright, left side	1
9	31-131-014	Gussets, bolt-on	2

ASSEMBLY

Numbers in parentheses correspond to item numbers in the *EXPLODED VIEW AND BILL OF MATERIALS*.

- Slide one end of the lower bar stiffener through the lower hole in the stiffener bracket of the right side upright (2); then insert a cotter pin through the pin hole in the end of the stiffener. Bend the arms of the pin around the stiffener.
- Insert one end of the upper bar stiffener (3) through the upper hole in the stiffener bracket of the right side upright. Secure the connection by inserting a cotter pin through the pin hole in the end of the stiffener. Bend the arms of the pin around the stiffener.
- Fasten the other ends of the stiffeners to the left side upright (8) in the same way as described in steps 1 & 2.

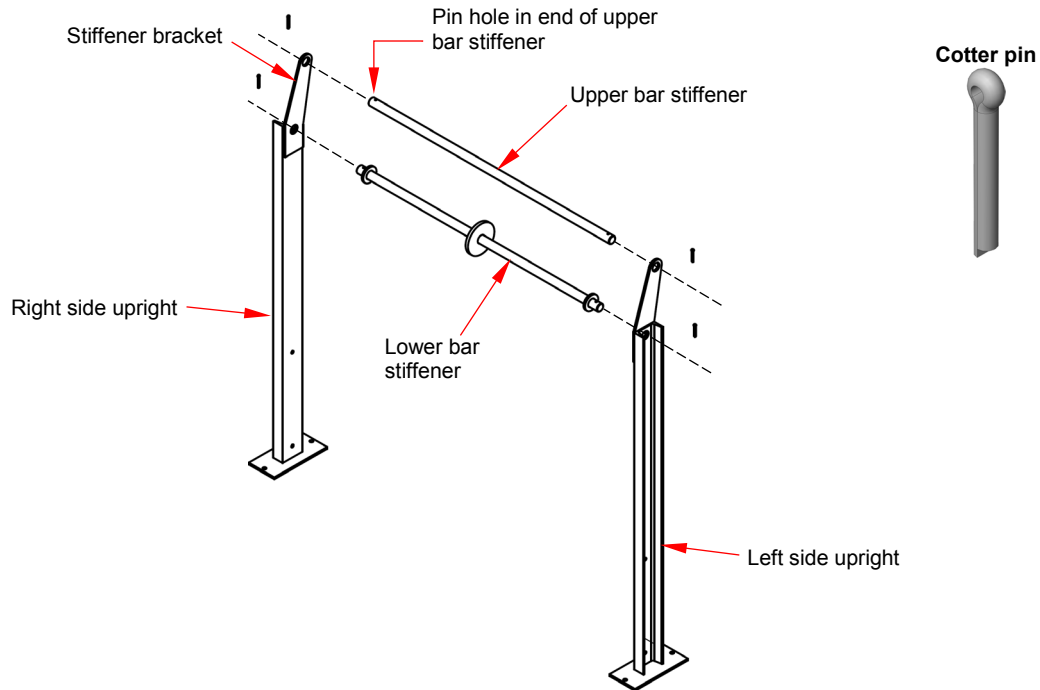

- Attach the uprights to the base weldment. Notice that the base has front and rear sides. Be sure to orient the uprights properly, so that the right and left side uprights attach to the correct mounting brackets on the base. Align the bolt holes in the uprights with the bolt holes in the mounting brackets; then drop bolts through the holes (2 on each upright; only 1 shown) and secure them with lock nuts.

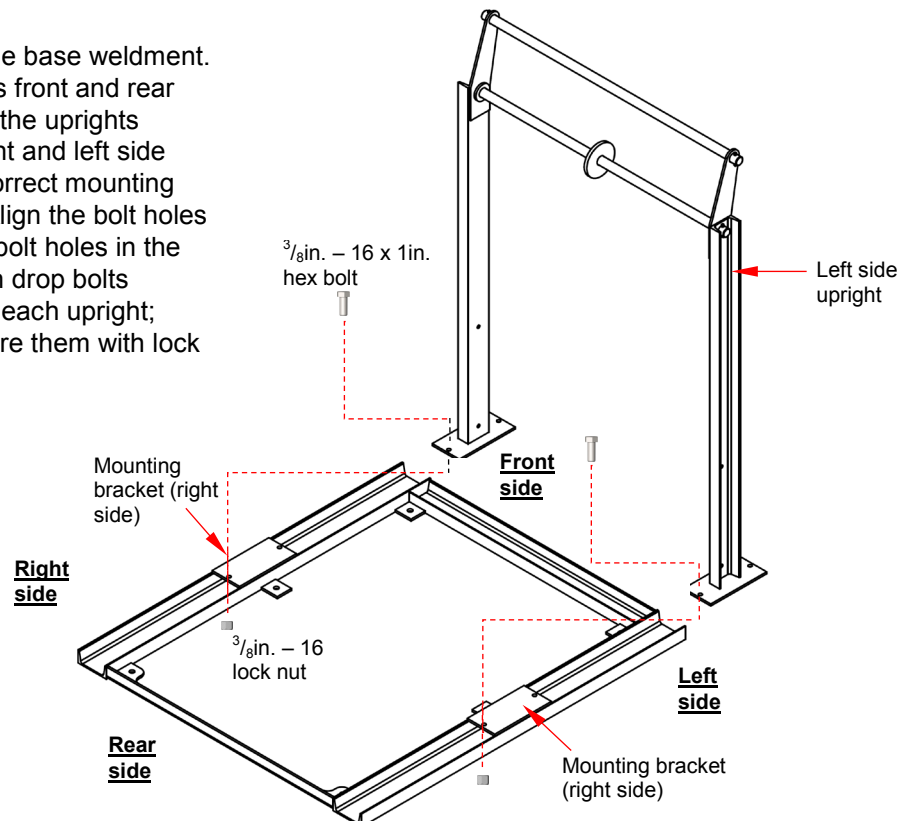

5. Attach gussets to the uprights. Align bolt holes in the gussets with bolt holes in the uprights. Install 2 hex bolts (11105) through each gusset. Secure the bolts with lock nuts (37024).

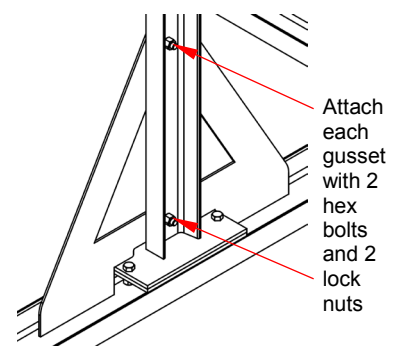
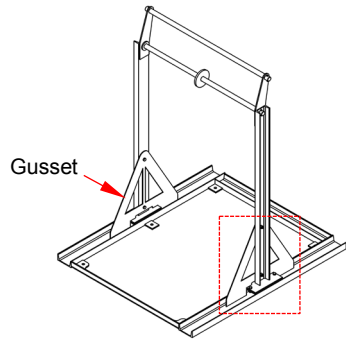

USING THE RACK

This rack is designed to allow a forklift operator to remove fork extensions without having to dismount the lift and remove them manually.

1. Slowly drive the forklift towards the front side of the rack.
2. Elevate the forks so that the tips of the fork extensions are slightly above the lower bar stiffener.
3. Slowly drive forward and adjust fork elevation to bring the underside of the tip of the fork extensions into contact with the lower stiffener. Only the extensions (not the forks) should rest on the lower stiffener.
4. Slowly lower the forks to separate the extensions from the forks.
5. Drive the forklift forward while adjusting fork elevation to set the tine loops inside the base channel. Lower the forks so the tine loops contact the front lip of the base channel.
6. Slowly drive the forklift in reverse to withdraw the forks from the tine loops.

Steps 1 & 2: Approach the rack & adjust fork elevation

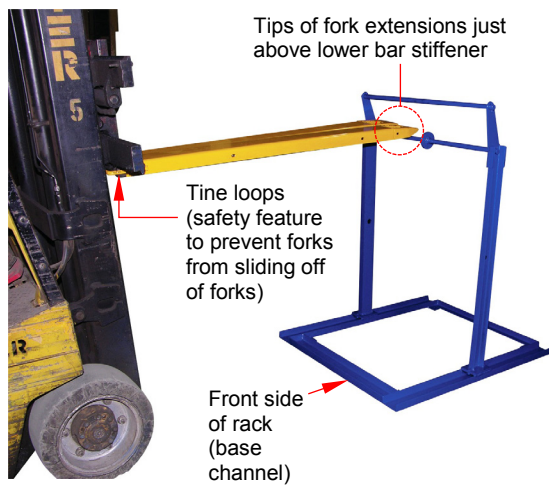

Steps 3 & 4: Rest tips of fork extensions on lower stiffener

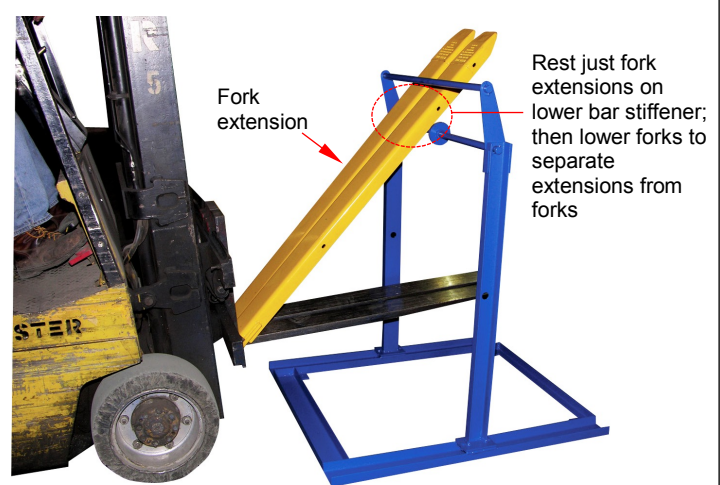

Steps 5 & 6: Set tine loops in base channel

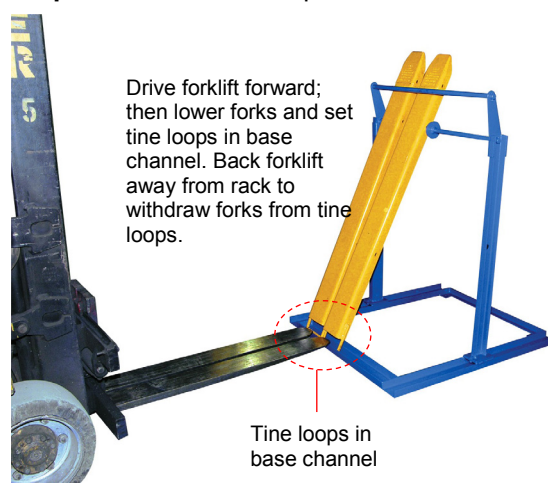

RECORD OF SATISFACTORY CONDITION

Before putting the unit into service, create a record of its condition and use. Include detailed descriptions about the frame, bar stiffeners, uprights, stiffener brackets, and all fasteners. Thoroughly photograph the unit including all labels applied to it. Add the photographs to the record. This record establishes normal condition. When conducting future inspections compare your observations to the record to determine if the unit, or a component of it, is in normal condition. Any part not in normal condition should be repaired or replaced before the unit is returned to service.

INSPECTIONS AND MAINTENANCE

NOTICE

Proper use, maintenance, and storage are essential for this product to function properly.

- Keep the product clean & dry. Lubricate moving parts at least once per month.
- ONLY use manufacturer-approved replacement parts. Vestil is not responsible for issues or malfunctions that result from the use of unapproved replacement parts.

If a problem is discovered during an inspection, restore the rack to normal operating condition BEFORE using it again. DO NOT use the rack if it is structurally damaged in any way. Structural damage includes, but is not limited to, cracked welds and warping or significant deformation of the uprights, frame, or bar stiffeners. Always completely unload the rack before conducting inspections.

Monthly inspection – check the following at least once per month:

1. Check machine bushings (between stiffener brackets and lower bar stiffeners), bolts and lock nuts, and cotter pins for soundness. Pins and fasteners should be unbroken. Machine bushings should not be severely worn.
2. Inspect the base weldment. Confirm that it is square and rigid and solidly anchored to the floor. The base should be free of rust and corrosion.
3. Examine the connection between the uprights and the mounting brackets (of the base weldment). Tighten lock nuts if necessary to remove looseness in the connections. Confirm that the mounting brackets are level and undamaged, and that bolt holes are not enlarged.
4. Inspect each bar stiffener for looseness and degree of wear. If a stiffener is bent, cracked, or severely worn replace it before returning the rack to service.
5. Make sure all labels are in place & in readable condition. See [Labeling diagram](#).
6. Clean dirt and debris from all surfaces of the rack.

LABELING DIAGRAM

Each unit should be labeled as shown in the diagram. However, label content and location are subject to change without notice so your product might not be labeled exactly as shown. Compare the diagram below to your [Record of Normal Condition](#). If there are any differences between actual labeling and this diagram, adapt the diagram to reflect actual labeling. Replace all labels that are damaged, missing, or not easily read (e.g. faded). To order replacement labels or to inquire whether your unit is properly labeled, contact the technical service and parts department online at http://www.vestilmfg.com/parts_info.htm or by calling (260) 665-7586 and asking for the Parts Department.

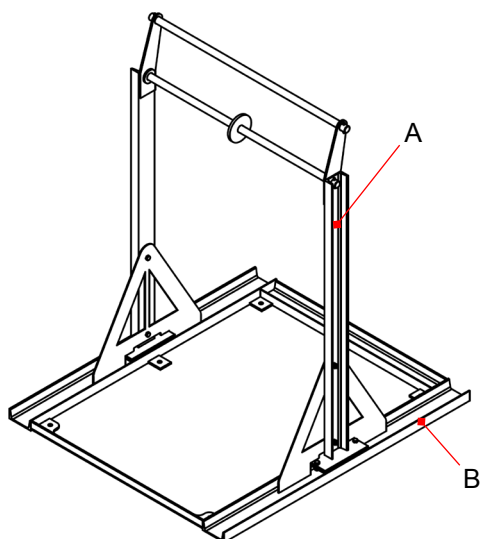

A: Label 287 Data label

MODEL/MODÉLO/MODÈLE _____
STATIC CAPACITY (evenly distributed) _____ lbs.
LA CAPACIDAD CONSTANTE (distribuida uniformemente) _____ kgs.
CAPACITÉ STATIQUE (distribuée régulièrement) _____ kgs.
SERIAL/SERIE/SÉRIE _____
287 REV 0812

B: Label 204 “Secure frame to floor”

▲ WARNING ▲ ADVERTENCIA ▲ AVERTISSEMENT		
SECURE FRAME TO FLOOR	ASEGURE EL BASTIDOR AL PISO	FIXER SOLIDEMENT LE CADRE AU PLANCHER
		<small>204 Rev 11/10</small>

LIMITED WARRANTY

Vestil Manufacturing Corporation (“Vestil”) warrants this product to be free of defects in material and workmanship during the warranty period. Our warranty obligation is to provide a replacement for a defective, original part covered by the warranty after we receive a proper request from the Warrantee (you) for warranty service.

Who may request service?

Only a warrantee may request service. You are a warrantee if you purchased the product from Vestil or from an authorized distributor AND Vestil has been fully paid.

Definition of “original part”?

An original part is a part used to make the product as shipped to the Warrantee.

What is a “proper request”?

A request for warranty service is proper if Vestil receives: 1) a photocopy of the Customer Invoice that displays the shipping date; AND 2) a written request for warranty service including your name and phone number. Send requests by one of the following methods:

<u>US Mail</u>	<u>Fax</u>	<u>Email</u>
Vestil Manufacturing Corporation 2999 North Wayne Street, PO Box 507 Angola, IN 46703	(260) 665-1339 <u>Phone</u> (260) 665-7586	info@vestil.com Enter “Warranty service request” in subject field.

In the written request, list the parts believed to be defective and include the address where replacements should be delivered. After Vestil receives your request for warranty service, an authorized representative will contact you to determine whether your claim is covered by the warranty. Before providing warranty service, Vestil will require you to send the entire product, or just the defective part (or parts), to its facility in Angola, IN.

What is covered under the warranty?

The warranty covers defects in the following original, dynamic parts: motors, hydraulic pumps, motor controllers, and cylinders. It also covers defects in original parts that wear under normal usage conditions (“wearing parts”), such as bearings, hoses, wheels, seals, brushes, and batteries.

How long is the warranty period?

The warranty period for original dynamic components is 30 days. For wearing parts, the warranty period is 90 days. Both warranty periods begin on the date Vestil ships the product to the Warrantee. If the product was purchased from an authorized distributor, the periods begin when the distributor ships the product. Vestil may, at its sole discretion, extend a warranty period for products shipped from authorized distributors by up to 30 days to account for shipping time.

If a defective part is covered by the warranty, what will Vestil do to correct the problem?

Vestil will provide an appropriate replacement for any *covered* part. An authorized representative of Vestil will contact you to discuss your claim.

What is not covered by the warranty?

The Warrantee (you) is responsible for paying labor costs and freight costs to return the product to Vestil for warranty service.

Events that automatically void this Limited Warranty.

- Misuse;
- Negligent assembly, installation, operation or repair;
- Installation/use in corrosive environments;
- Inadequate or improper maintenance;
- Damage sustained during shipping;
- Collisions or other accidents that damage the product;
- Unauthorized modifications: Do not modify the product IN ANY WAY without first receiving written authorization from Vestil.

Do any other warranties apply to the product?

Vestil Manufacturing Corp. makes no other express warranties. All implied warranties are disclaimed to the extent allowed by law. Any implied warranty not disclaimed is limited in scope to the terms of this Limited Warranty. Vestil makes no warranty or representation that this product complies with any state or local design, performance, or safety code or standard. Noncompliance with any such code or standard is not a defect in material or workmanship.

